

SAFE.  
FAST.  
SMARTCHECK.



## STILL ACCURATE? CHECKED!

**SmartCheck** – In offering this new tester for torque wrenches and torque screwdrivers, STAHLWILLE is launching a versatile, easy-to-handle tool that will find a home in any workshop and service vehicle. Thanks to its compact dimensions, the ability to mount it horizontally or vertically, and the revolving display, it can be used virtually anywhere – and is easy to use, too. SmartCheck quickly provides information on whether or not a torque wrench is still within the prescribed tolerances or whether it requires adjustment.

## VERSATILE.

SmartCheck can be positioned almost anywhere. Whether horizontally or vertically – the well-thought-out fixing points, the compact construction and rotatable display make it easy to use.



## ACCURATE.

The display deviation value of a mere  $\pm 1\%$  guarantees the greatest possible measuring dependability.

## READY FOR WORK.

Thanks to the integrated transducer with a broad measuring range, work can start immediately.

## ROBUST.

The integrated visual and audible overload protection mechanism ensures the durability customers expect of STAHLWILLE.



## INDIVIDUAL.

Three operating modes (track, first peak, peak hold) and three measuring units (N-m, ft-lb, in-lb) can be selected. The target torque and tolerances can be individually set to evaluate the readings.

## MOBILE.

Ideal for use on the road if there are no power sockets available. Besides the usual operating mode using a mains adapter, this unit can be run on batteries (4 x AAA or 1 x 9 V block, adapter included).

## REVOLUTIONARY.

SmartCheck can easily be adjusted to suit the user's angle of sight. Not on the display but also the display mount and base body can be rotated through 180°.

## INTUITIVE OPERATION.

The unit is easy to use and has operator guidance to aid fast working, reliable results coupled with high levels of safety.



## RESILIENT.

The display and keypad are splash-proof, and the housing is made of impact-resistant plastic. Safe transport and storage is ensured by the sturdy transport box.



### Additional benefits:

- **For many torque ranges:** SmartCheck is available for these standard torque ranges: 1-10 N-m, 10-100 N-m, 40-400 N-m and 80-800 N-m.
- **For starters:** STAHLWILLE will soon be expanding the torque tester group of products. The focus will always be on versatility, performance and ease of use. Smart? And checked!

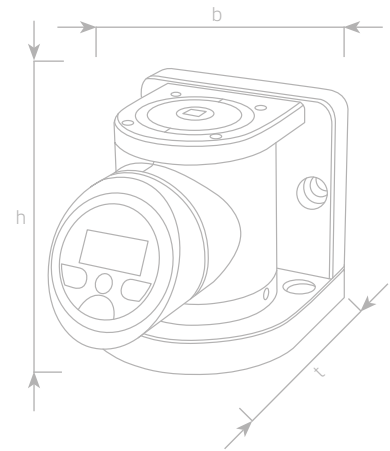

### SmartCheck torque tester

Code	No	N·m	ft·lb	in·lb	Ø "	b mm	h mm	t mm	±g
96 52 12 01*	SmartCheck 10S	1-10	0.74-7.4	8.9-88.5	1/4	120	124	167	5210
96 52 12 02	SmartCheck 10	1-10	0.74-7.4	8.9-88.5	1/4	120	124	167	5210
96 52 12 03	SmartCheck 100	10-100	7-74	89-885	3/8	120	124	167	5310
96 52 12 04	SmartCheck 400	40-400	30-295	354-3540	3/4	120	124	167	5690
96 52 12 05	SmartCheck 800	80-800	59-590	708-7081	3/4	120	124	167	5690

\* For testing torque screwdrivers



